

## CONSTRUCTION SPECIFICATIONS

CONCRETE PROPERTIES 5000psi ( 35Mpc ) Minimum Strength  
4-7% Air Entrainment

RISER COVER MAY BE USED WITH EXTENSIONS

PLASTIC INLET AND OUTLET BAFFLE

4" INLET/OUTLET

MEETS CSA-B66-05

REINFORCING MEETS: G30.14.M1983

ASTM C1116 TYPE III

### ENGINEERED FOR 1M OF BURIAL DEPTH

#### MATERIALS:

CONCRETE: TYPE 10 PORTLAND, 35MPa AT 28 DAYS  
STANDARD SEE B66-05 SECTION 5

#### NOTES:

1. DELIVERY IS MADE BY CRANE EQUIPPED TRUCKS  
EXCAVATION SHOULD BE 1FT LARGER THAN THE TANK  
MINIMUM DIMENSIONS AND ACCESSIBLE FOR UNLOADING  
FRONT THE REAR OF THE TRUCK  
MINIMUM OVERHEAD CLEARANCE OF 18FT IS REQUIRED

2.FOR INSTALLATION INSTRUCTIONS REFER TO CSA AND  
STANDARD PRACTICE MANUALS

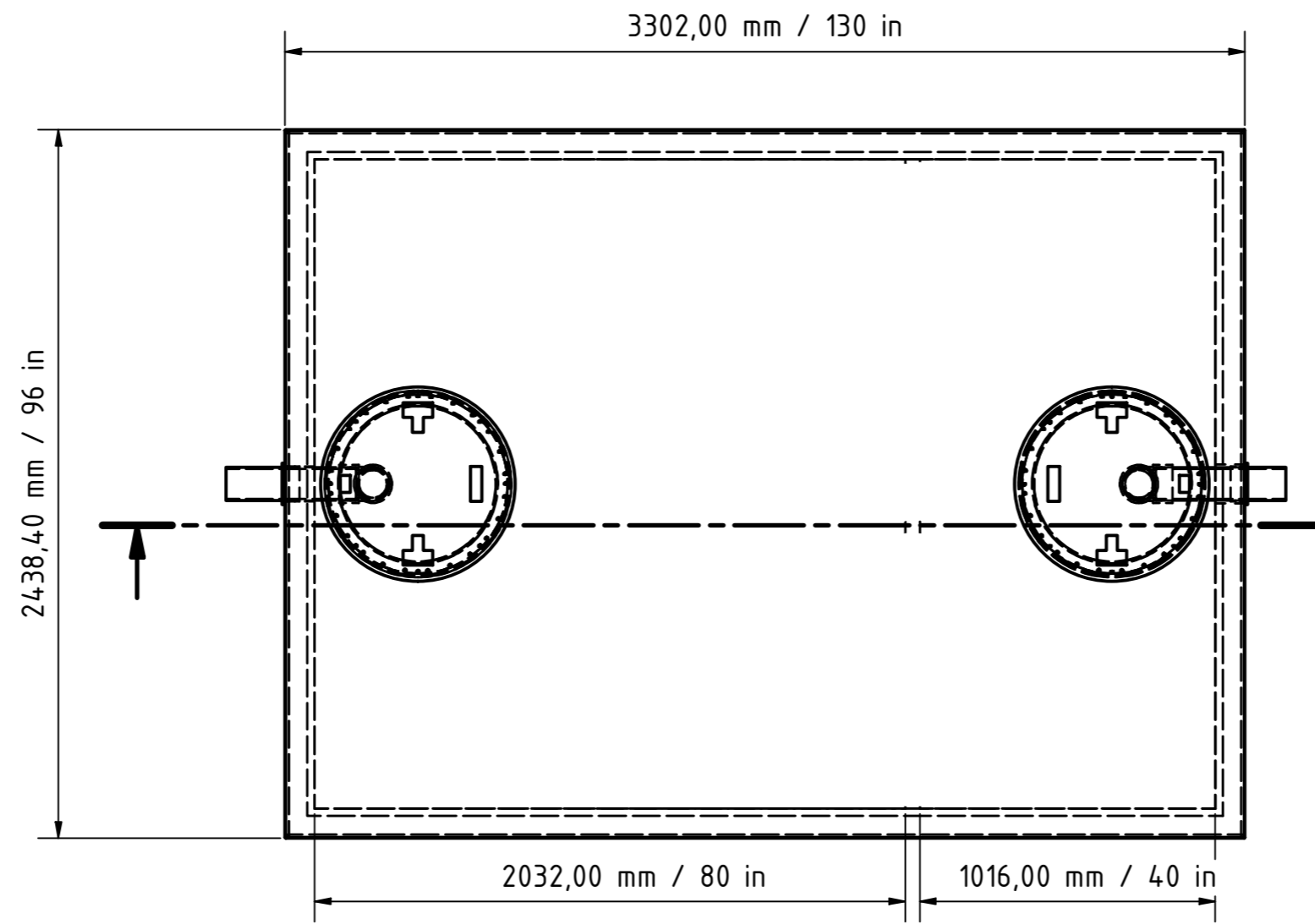

TOP

24" POLYLOK LID  
24" MANWAY

24" POLYLOK LID  
24" MANWAY

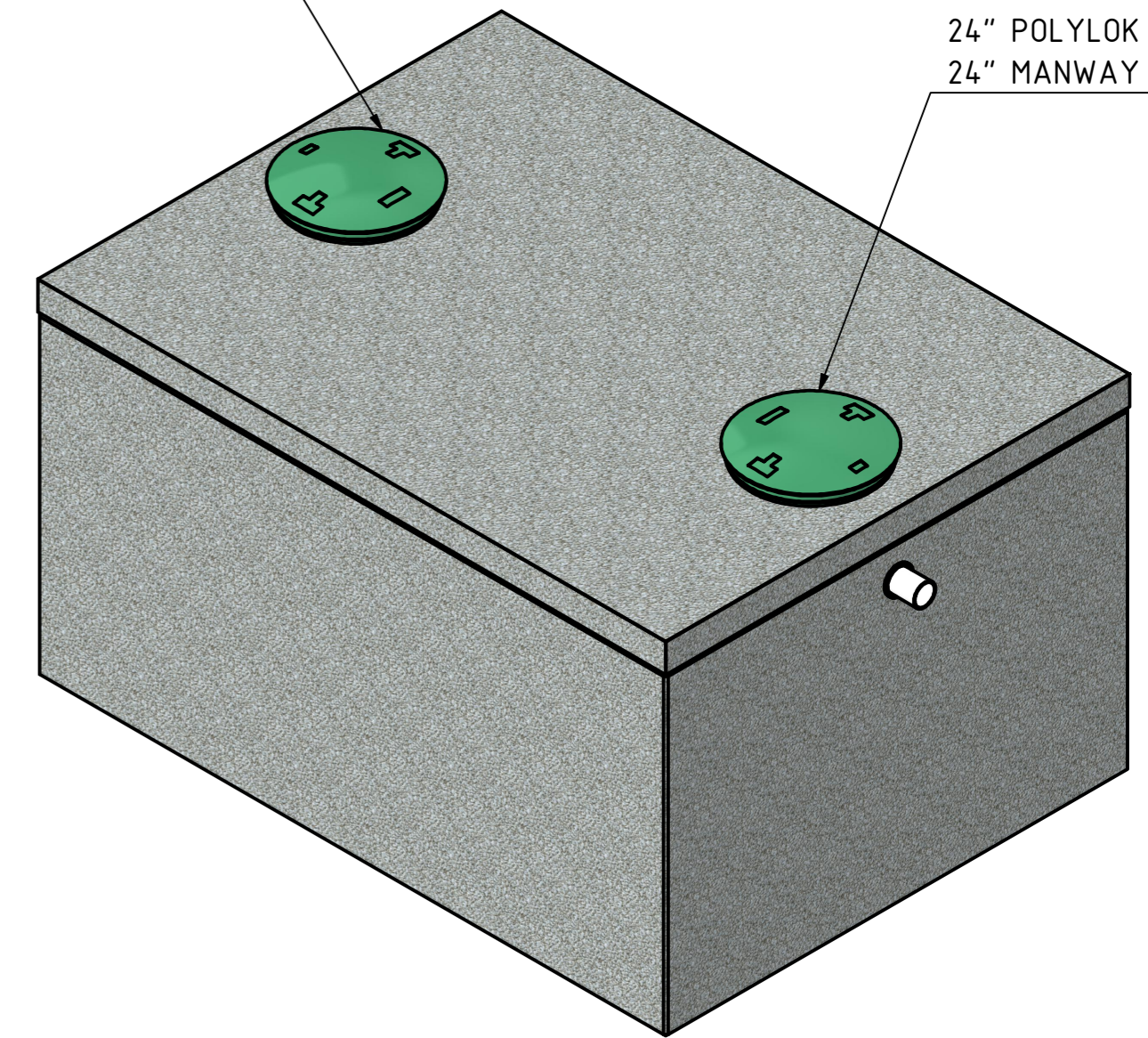

TOP

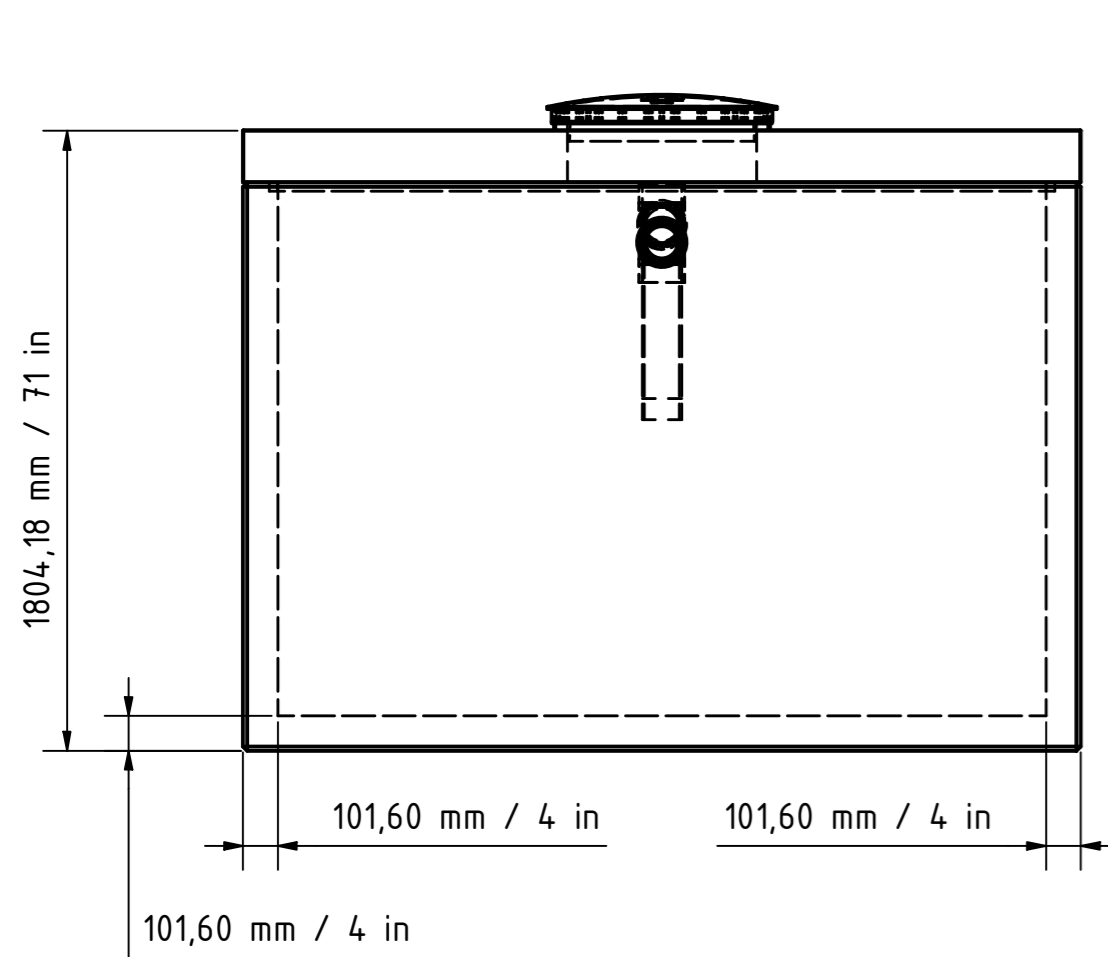

FRONT VIEW

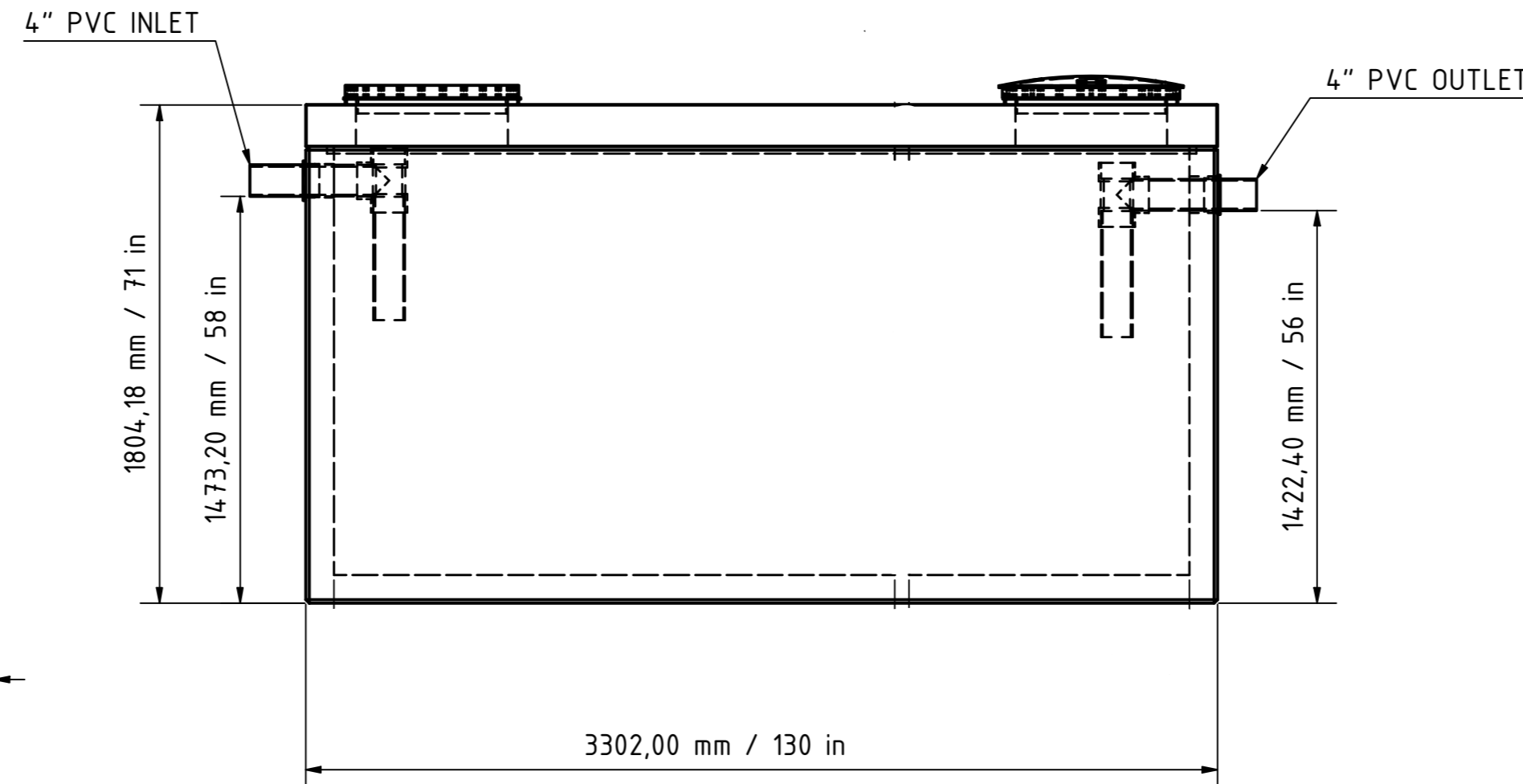

WEIGHT - 20,000 LBS  
IMP GALLONS PER INCH - 38



DRAWN BY:DBK	DATE 2023-04-09
MANCO SEPTIC SOLUTIONS	
2000 IMP GALLON PUMP CHAMBER	